



Pumps for the sugar industry



Luftreportagen Hausmann, Wien

seepex progressive cavity pumps in the sugar industry

Sugar mills are classified into the areas of: the **receiving yard**, which includes beet or cane washing and effluent treatment; the **juice house**, which includes juice ex-

traction, juice classification, juice thickening and pulp drying; and the **sugar house**, which incorporates crystallization with sugar refining.

The sugar

Sugar, chemically sucrose, is an integral component of many plant juices. Sugar beets and cane contain an extraordinary amount of sucrose. Sucrose is a disaccharide, i.e. one molecule links both glucose and fructose, as a general type of carbohydrate.

The world's sugar production is derived 35% from the extraction of sucrose from beets and 65% from sugar cane. Over 100 million tons of sugar are produced, globally, each year.

Sugar cane grows only in tropical climates; whereas, the sugar beet can grow in countries with mild climates.

The sucrose content of the sugar beet is 14-17%, while sugar cane has a sucrose content of 11-16%.

These low sugar concentrations require extractive refining with large volumes of liquids, additional chemicals and mechanical aids. Throughout the many steps in the process, **seepex** pumps provide useful and reliable service, to this vital industry.

Applications for seepex pumps in the sugar industry

seepex pumps with their unique advantages are used worldwide in almost all areas of the sugar refining industry. Their most common uses are in the areas of juice extraction, juice purification, juice thickening, juice crystallization and waste treatment. Lastly, they are used for the difficult transport of dewatered sludges.

In the receiving yard:

- 1 Beet wash-sludge, SG 1.16 kg/dm³, solids of approx. 40% ds

In juice extractions:

- 2 Raw Juice, solids approx. 15% ds temperature approx. 50-60° C / 122-140° F

In pulp drying:

- 3 Molasses, solids approx. 82 - 85% ds, temperature approx. 45-55° C / 113-131° F

In juice purification:

- 4 Raw Juice, lime added, pH value > 11
- 5 Lime Milk, solids approx. 25% ds, temperature approx. 40° C / 104° F
- 6 Raw Juice, carbonated (Juices + CaCo₃), temperature approx. 90° C / 194° F.

- 7 Thickened Juice Sludge, (Juice + CaCo₃, thickened), temperature approx. 80-90° C / 176-194° F

- 8 Carbolime, solids up to 54% ds temperature approx. 30-40° C / 86-104° F

In juice evaporation

- 9 Thin Juice, temperature approx. 90° C / 194° F.
- 10 Syrup from evaporation, solids approx. 70% ds, temperature approx. 80-90° C / 176-194° F

In crystallization:

- 11 12 Run Off e.g. A-Run Off, White Run Off
- 13 14 Green Molasses (high and low), B-Run Off, Crystallizer Run Off, C-Run Off, Molasses solids approx. 70-85% ds, temperature approx. 40-70° C / 86-158° F
- 15 Clear Syrup, solids approx. 70% ds, temperature approx. 80° C / 176° F
- 16 Seed (Sugar crystals and molasses), temperature approx. 50° C / 122° F
- 17 Magma and Masseccuite, Crystals in suspension, temperature approx. 40-75° C / 86-167° F
- 18 Water and condensate

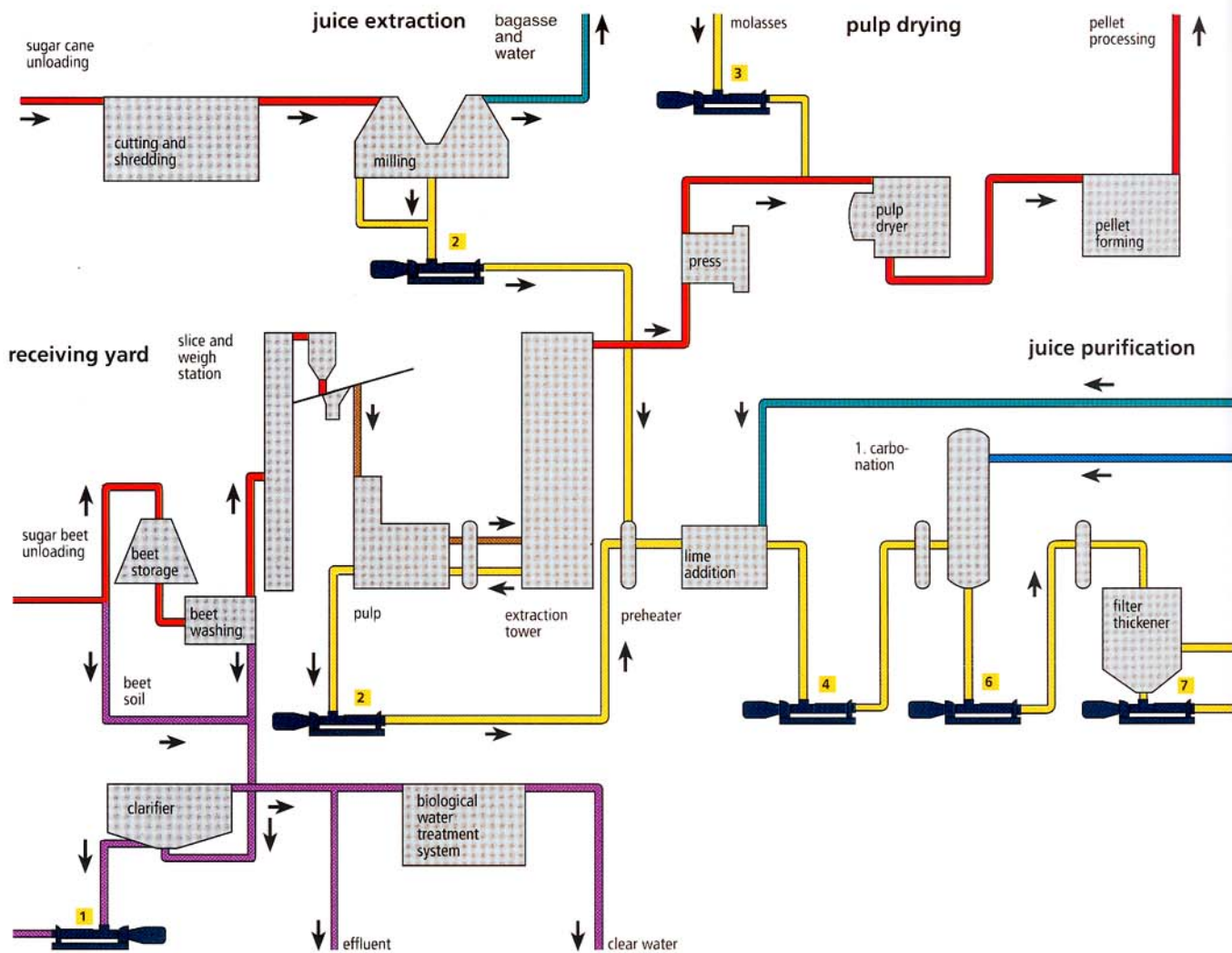

seepex pumps in the refining process of the sugar industry

- beets (shredded), cane
- beet soil, sludge
- juice, run off
- water, condensate
- lime milk
- carbonic acid
- spent steam
- sugar
- cooked mash
- air



Receiving Yard
Two variable speed seepex pumps N 350-6L mounted on a rotating clarifier bridge, **product:** thickened sludge, **flow:** 65-265 m³/h / 286-1170 usgpm, **speed:** 65-255 rpm, **pressure:** 2 bar / 28 psig, **solids:** up to 35% ds



Juice Purification
VFD controlled seepex pump BN 2-6L, **product:** thickened juice sludge, **flow:** 0.6-2 m³/h / 2.65 - 8.8 usgpm, **speed:** 100-305 rpm, **pressure:** 2.24 bar / 32 psig, **viscosity:** 60 mPas, **SG:** 1.4 kg/dm³



Pulp Drying
VFD controlled seepex pump BN 17-6L, **product:** molasses, **flow:** 5-15 m³/h / 22-66 usgpm, **speed:** 125-310 rpm, **pressure:** 4.6 bar / 65 psig, **temperature:** 70° C / 158° F, **viscosity:** 200-500 mPas, **SG:** 1.4 kg/dm³ and a seepex pump BN 5-24, **product:** molasses, **flow:** 5 m³/h / 22 usgpm, **speed:** 400 rpm, **pressure:** 14.2 bar / 202 psig, **temperature:** 55° C / 131° F, **viscosity:** 1800-7000 mPas, **SG:** 1.4 kg/dm³

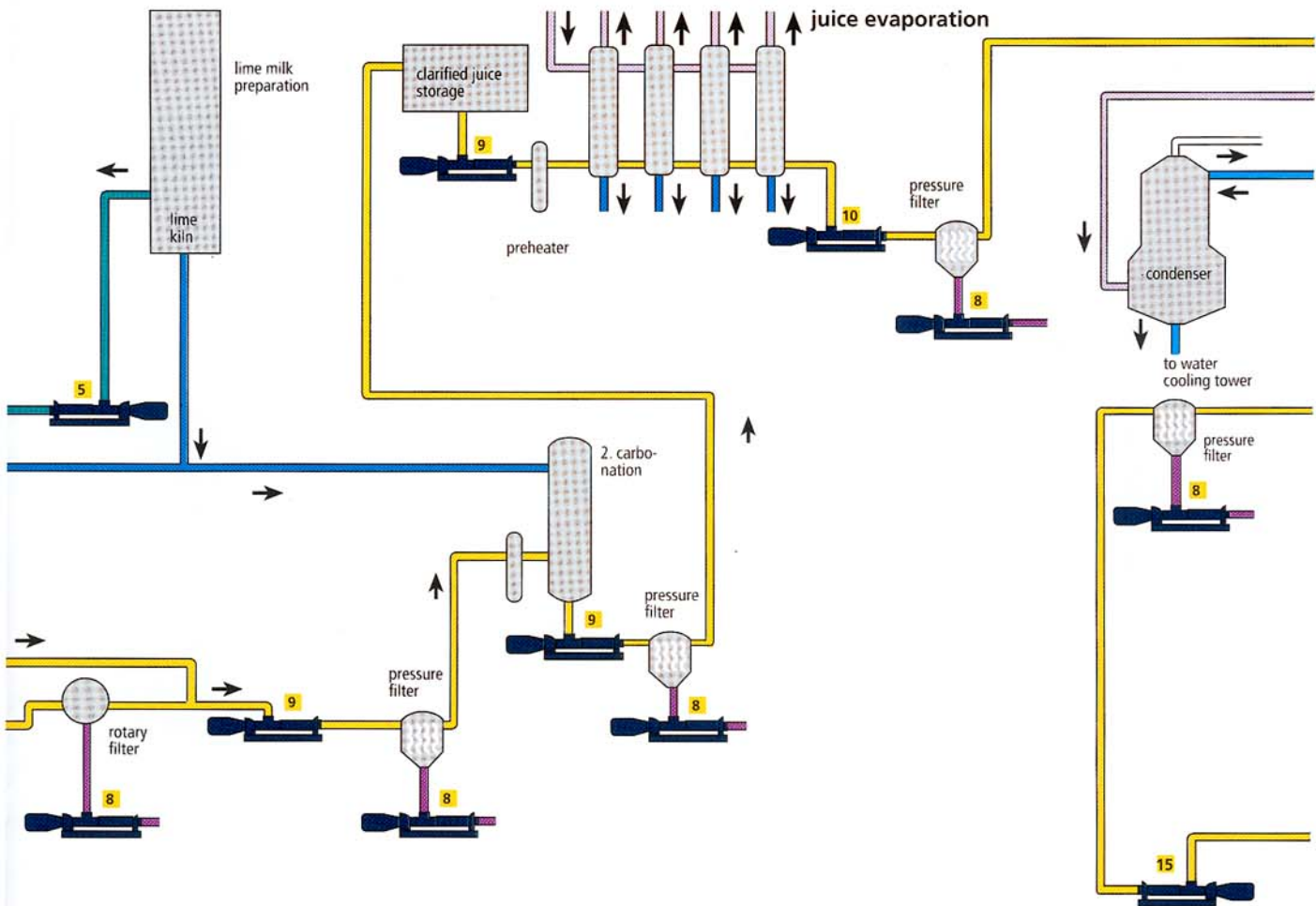

Juice Purification
under a rotary vacuum filter.
Three seepex pumps
BN 10-12 and
BT 17-6L with
adjustable stator
retensioning device,
product: carbolime,
flow: 1.7 and 6 m³/h / 7.5
and 26.5 usgpm,
speed: 70 and
120 rpm,
pressure: 3 and
6 bar / 43 and 85 psig,
solids: 40 and 50% ds



Juice Thickening
Two seepex pumps
BN 70-12, product:
syrup from thickening to crystallization,
flow: 70 m³/h / 308 usgpm,
speed: 370 rpm,
pressure: 11 bar / 156 psig,
temperature: 15° C / 59° F, viscosity: 822 mPas,
SG: 1.37 kg/dm³



Crystallization
A seepex pump
BN 35-12, product:
thick juice,
flow: 25 m³/h / 110 usgpm,
speed: 300 rpm,
pressure: 10.3 bar / 146 psig,
temperature: 15° C / 59° F,
viscosity: 822 mPas,
SG: 1.37 kg/dm³



Crystallization
A seepex pump
N 350-6L, product:
crystallizer run off,
flow: 140 m³/h / 616 usgpm,
speed: 142 rpm,
pressure: 2-3 bar / 29-43 psig, suction
pressure: with
vacuum 75 mbar,
at 3 mWc positive
head, temperature:
50° C / 122° F,
viscosity: 309 mPas,
solids: 78% ds

and a seepex pump
BN 70-12, product:
crystallizer run off,
flow: 19-43 m³/h /
84-189 usgpm,
speed: 89-197 rpm,
pressure: 3-6 bar / 43 -
86 psig, suction
pressure: with
vacuum 80-85 mbar,
at 3 mWc positive head,
temperature:
50° C / 122° F,
viscosity: 309 mPas,
solids: 78% ds

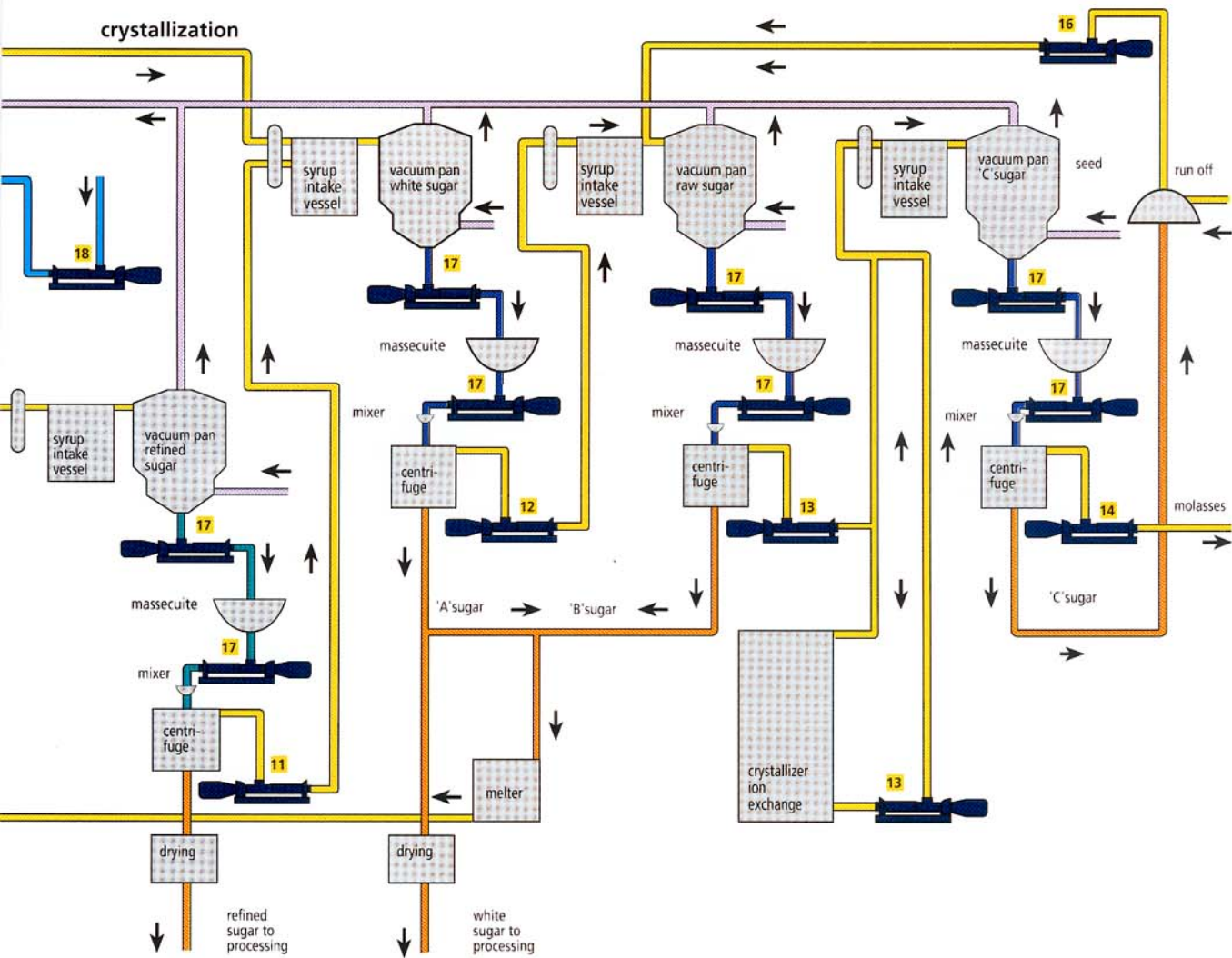

Crystallization
Four seepex pumps
BN 35-6L,
product: high and
low green molasses,
flow: 4-25 m³/h /
18-110 usgpm,
speed: 50-280 rpm,
pressure: 2.7-3.2
bar / 40-45 psig,
temperature:
70-85° C / 158-185°F,
solids: 60-70% ds



Crystallization
seepex pump
BN 17-6L, product:
'A' sugar run off,
flow: 13 m³/h /
57 usgpm, speed:
265 rpm, pressure:
2.66 bar / 38 psig,
temperature: 50° C /
122° F,
viscosity: 200 mPas,
SG: 1.4 kg/dm³



Crystallization
seepex pumps
BN 17-24, product:
molasses, flow:
15 m³/h / 66 usgpm,
speed: 360 rpm,
pressure: 12 bar /
170 psig,
temperature: 55° C /
131° F,
viscosity: 7000 mPas,
SG: 1.4 kg/dm³



Crystallization
VFD controlled
seepex pump
BN 5-12,
product: molasses,
flow: 1.7-5 m³/h /
7.5-22 usgpm,
speed:
165-400 rpm,
pressure: 6.72 bar /
96 psig,
temperature: 55° C /
131° F,
viscosity: 7000 mPas,
SG: 1.4 kg/dm³



Your **seepex** agent